

# ERCOFTAC SIG15 TEST CASE

## ベンチマーク進捗報告

[http://www.ercoftac.org/fileadmin/user\\_upload/bigfiles/sig15/database/index.html](http://www.ercoftac.org/fileadmin/user_upload/bigfiles/sig15/database/index.html)

北風 慎吾

# ERCOFTAC(European Research Community of Flow, Turbulence and Combustion)

・・・テーマごとにグループ分けされていて、研究活動が行われている(燃焼・混相・粒子法etc)。

その中の乱流モデリングのグループ(SIG15)が過去に開催したworkshopにおいて実施されたベンチマークのデータベースがある(この他にマンチェスター大が管理するClassic版も→富原さん@関西)

## Special Interest Groups

username   
password

| Special Interest Groups                                                                                                                                                                                                                                                                                                                                                                                                                                                                                                                                                                                                                                                                                                                                                                                                                                                             | Special Interest Groups (SIG)                                                                                                                                                                                                                                                                                                                                                                                                                                                                                                                                                                                                                                                                                                                                                                                                                                                                                                                                                                                                                                                                                                                                                                                                                                                                                                                                                                                                                                                                                                                                                                                                                                                                                                                                                                                                                                                                                                                                                                                                                                                                                                                                                                              | Latest Forum Posts                                                                                                                                                                                                                                                                                                                                                                                                                                                                                                                                                                                                                                                                                                                                          |
|-------------------------------------------------------------------------------------------------------------------------------------------------------------------------------------------------------------------------------------------------------------------------------------------------------------------------------------------------------------------------------------------------------------------------------------------------------------------------------------------------------------------------------------------------------------------------------------------------------------------------------------------------------------------------------------------------------------------------------------------------------------------------------------------------------------------------------------------------------------------------------------|------------------------------------------------------------------------------------------------------------------------------------------------------------------------------------------------------------------------------------------------------------------------------------------------------------------------------------------------------------------------------------------------------------------------------------------------------------------------------------------------------------------------------------------------------------------------------------------------------------------------------------------------------------------------------------------------------------------------------------------------------------------------------------------------------------------------------------------------------------------------------------------------------------------------------------------------------------------------------------------------------------------------------------------------------------------------------------------------------------------------------------------------------------------------------------------------------------------------------------------------------------------------------------------------------------------------------------------------------------------------------------------------------------------------------------------------------------------------------------------------------------------------------------------------------------------------------------------------------------------------------------------------------------------------------------------------------------------------------------------------------------------------------------------------------------------------------------------------------------------------------------------------------------------------------------------------------------------------------------------------------------------------------------------------------------------------------------------------------------------------------------------------------------------------------------------------------------|-------------------------------------------------------------------------------------------------------------------------------------------------------------------------------------------------------------------------------------------------------------------------------------------------------------------------------------------------------------------------------------------------------------------------------------------------------------------------------------------------------------------------------------------------------------------------------------------------------------------------------------------------------------------------------------------------------------------------------------------------------------|
| <ul style="list-style-type: none"><li>Large Eddy Simulation</li><li>Turbulence in Compressible Flows</li><li>Environmental CFD</li><li>Transition Modelling</li><li>Dispersed Turbulent Two Phase Flow</li><li>Stably Stratified and Rotating Turbulence</li><li>Turbulence Modelling</li><li>Drag Reduction and Flow Control</li><li>Variable Density Turbulent Flows</li><li>Particle Image Velocimetry</li><li>Reactive Flows</li><li>Transition Mechanisms, Prediction and Control</li><li>Design Optimization</li><li>Multipoint Turbulence Structure and Modelling</li><li>Swirling Flows</li><li>Bio-Fluid Mechanics and Heat Transfer</li><li>Microfluidics and Micro Heat Transfer</li><li>Aeroacoustics</li><li>Smoothed Particle Hydrodynamics (SPH)</li><li>Fluid Structure Interaction</li><li>Synthetic Models in Turbulence</li><li>Fibre Suspension Flows</li></ul> | <p><b>Special Interest Groups (SIG)</b></p> <p>ERCOFTAC Special Interest Groups form the second pillar of the Association. SIG are composed of ERCOFTAC members working together on a well defined specific topic on Flow, Turbulence and Combustion.</p> <p>Activities of Special Interest Groups are organising Workshops, Comparison of Codes, Exchange of Research Results, Creation of Experimental and/or Numerical Data Bases, Organisation of Courses, ...</p> <p>ERCOFTAC Special Interest Groups are associated with at least two <u>Pilot Centres</u>, and have an international organising committee.</p> <p><b>SIGs are active on the following topics:</b></p> <ul style="list-style-type: none"><li>SIG 1: <a href="#">Large Eddy Simulation</a></li><li>SIG 4: <a href="#">Turbulence in Compressible Flows</a></li><li>SIG 5: <a href="#">Environmental CFD</a></li><li>SIG 10: <a href="#">Transition Modelling</a></li><li>SIG 12: <a href="#">Dispersed Turbulent Two Phase Flow</a></li><li>SIG 14: <a href="#">Stably Stratified and Rotating Turbulence</a></li><li><b>SIG 15: <a href="#">Turbulence Modelling</a></b></li><li>SIG 20: <a href="#">Drag Reduction and Flow Control</a></li><li>SIG 24: <a href="#">Variable Density Turbulent Flows</a></li><li>SIG 28: <a href="#">Reactive Flows</a></li><li>SIG 32: <a href="#">Particle Image Velocimetry</a></li><li>SIG 33: <a href="#">Transition Mechanisms, Prediction and Control</a></li><li>SIG 34: <a href="#">Design Optimization</a></li><li>SIG 35: <a href="#">Multipoint Turbulence Structure and Modelling</a></li><li>SIG 36: <a href="#">Swirling Flows</a></li><li>SIG 37: <a href="#">Bio-Fluid Mechanics and Heat Transfer</a></li><li>SIG 38: <a href="#">Microfluidics and Micro Heat Transfer</a></li><li>SIG 39: <a href="#">Aeroacoustics</a></li><li>SIG 40: <a href="#">Smoothed Particle Hydrodynamics</a></li><li>SIG 41: <a href="#">Fluid Structure Interaction</a></li><li>SIG 42: <a href="#">Synthetic Models in Turbulence</a></li><li>SIG 43: <a href="#">Fibre Suspension Flows</a></li></ul> <p>Missing numbers correspond to SIGs no longer believed to be active. All requests for</p> | <ul style="list-style-type: none"><li> ERCOFTAC's new web-site is now launched. SIG and PC...8 October 2010</li><li> Welcome to ERCOFTAC discussions. Please post here...8 October 2010</li><li> Welcome to ERCOFTAC discussions. Please post here...8 October 2010</li><li> Discussion group for Fibre Suspension Flows...17 December 2009</li><li> Discussion group for Reactive Flows...17 December 2009</li><li> Discussion group for Drag Reduction and Flow Control...17 December 2009</li><li> Welcome to ERCOFTAC discussions. Please post here...16 December 2009</li><li> Welcome to ERCOFTAC discussions. Please post here to...4 December 2009</li><li> ...3 December 2009</li><li> Discuss ERCOFTAC web-site issues...1 October 2009</li></ul> |

とりあえず、ケースファイル作りに精を出しており、検証はあまり進まず (赤線枠内が解析済み)  
 以下は**4TH WORKSHOP**から**6TH WORKSHOP**まで、このくらいまでは割と基礎的な流れがメイン  
 青枠のケースは機能改良が必要だったり、境界条件がよくわかってなくて、不完全なものです

4th workshop at the University of Karlsruhe (3-7 April 1995)

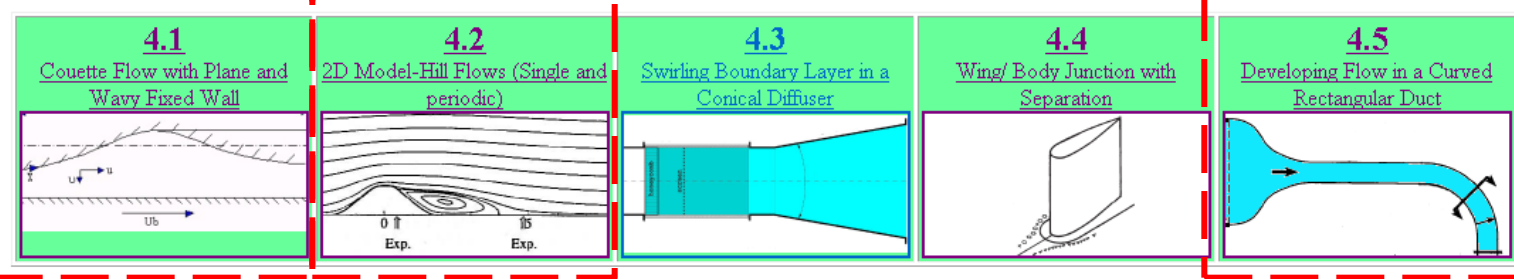

5th workshop at EDF Chatou (25-26 April 1996)

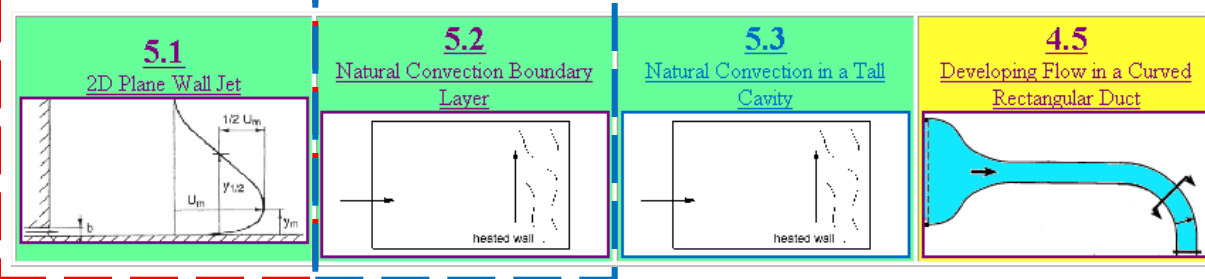

ちなみに...  
 CASE4.3はOpenfoamWikiの  
 Turbomachineryグループが  
 例題をHP上に用意しています

6th workshop at Delft University of Technology (6-7 June 1997)

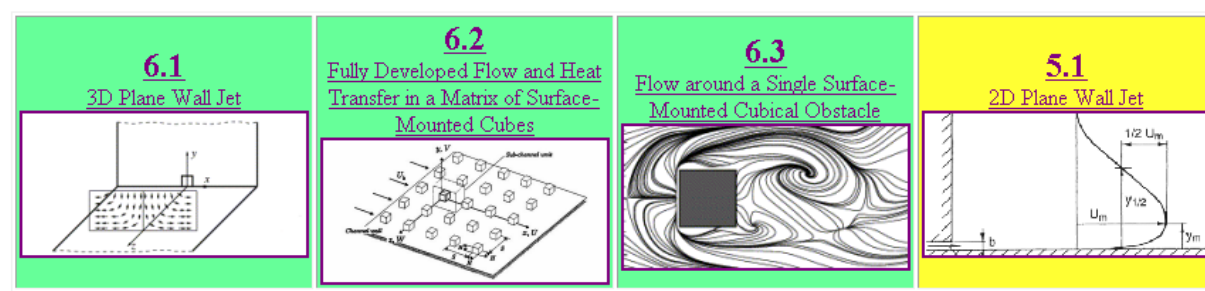

7th workshop at UMIST (28-29 May 1998)

徐々に流れが複雑になっていっています

モデリングで困っているのは主流方向に周期境界条件を使うもの(ここでは**CASE7.2, 7.3, 9.2**など)

→掲示板で教えてもらいましたが、うまくいかず。発達した流れを作るのに周期構造をわざわざモデリング!

### 7th workshop at UMIST (28-29 May 1998)

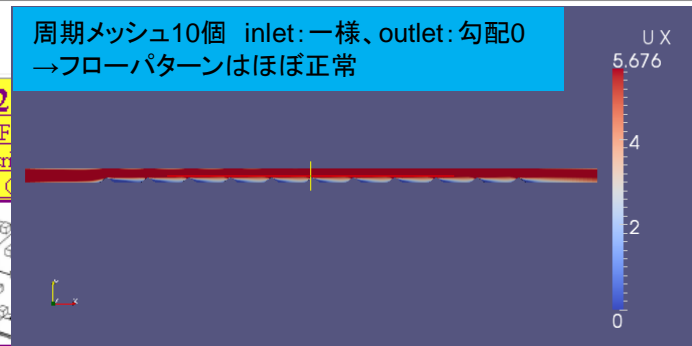
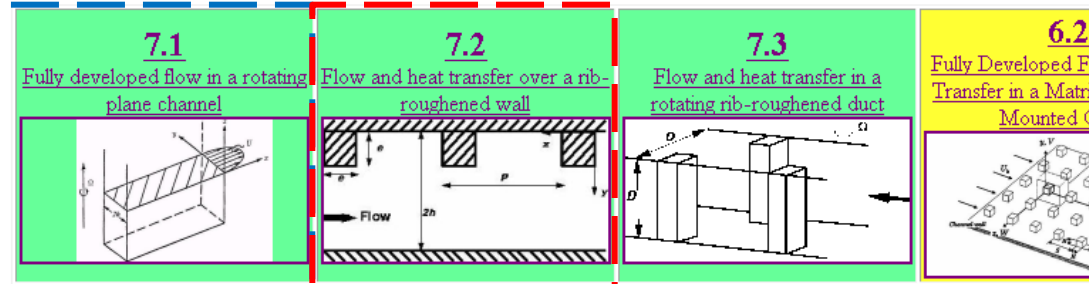

### 8th workshop at Helsinki University of Technology (17-18 June 1999)

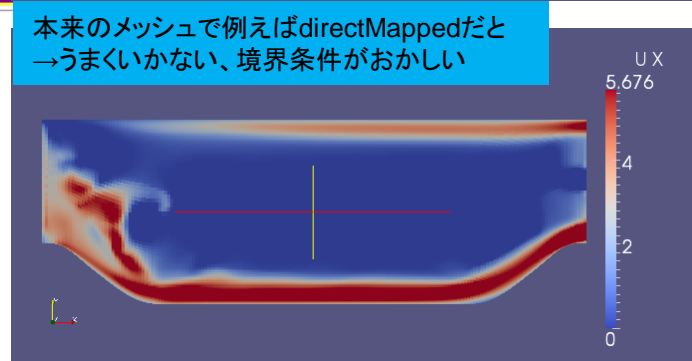
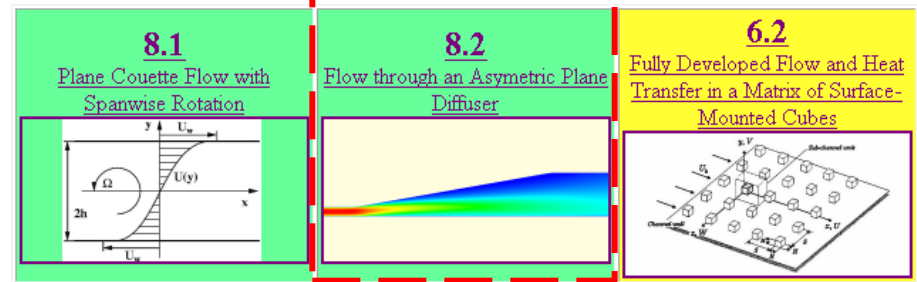

### 9th workshop at Darmstadt University of Technology (4-5 October 2001)

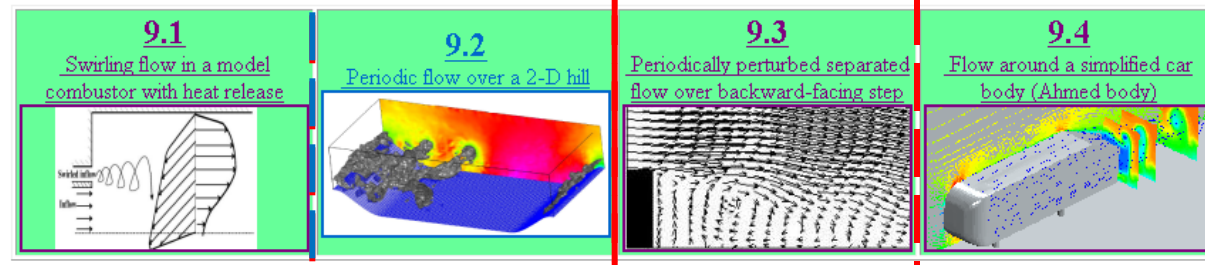

### 10th workshop at University of Poitiers (10-11 October 2002)

## 10th workshop at University of Poitiers (10-11 October 2002)

**10.1**

Contra-rotating jets

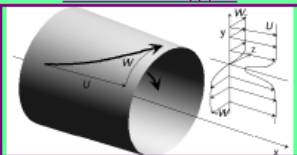

**9.2**

Periodic flow over a 2-D hill

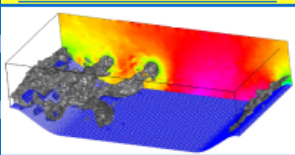

**9.4**

Flow around a simplified car body (Ahmed body)

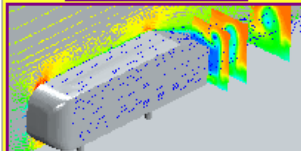

**11<sup>TH</sup>**以降はかなり実問題を対象にしているためか、**3次元問題**が中心手が回ってないせいもあって、ほとんどがモデリングすら未達の状態です...

## 11th workshop at Chalmers University of Technology (7-8 April 2005)

**11.1**

2D hump with flow control through a slot jet

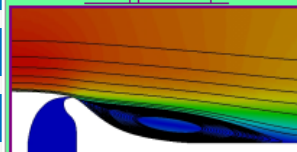

**11.2**

Flow over an axisymmetric 3D hill

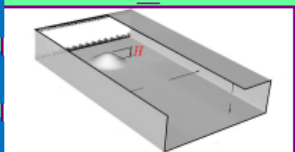

**11.3**

Slanted jets in cross-flow

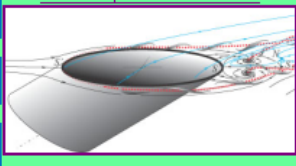

**11.4**

Multiple-impinging jets: flow and heat transfer

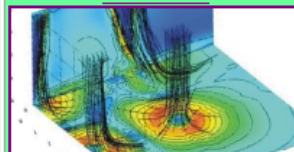

## 12th workshop at Technical University of Berlin (12-13 October 2006)

**12.1**

Tip-gap turbulent flow in a low-speed compressor cascade

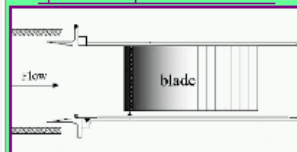

**12.2**

A model of tubo-annular swirl combustor

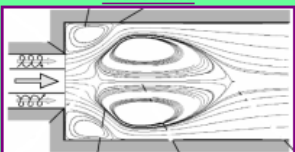

**11.1**

2D hump with flow control through a slot jet

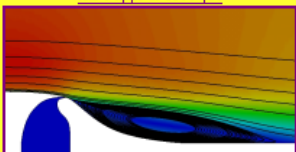

**11.2**

Flow over an axisymmetric 3D hill

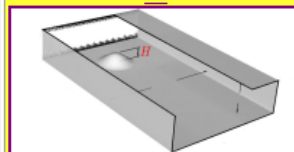

## 13th workshop at Graz University of Technology (25-26 September 2008)

**13.1**

Round jet impinging onto a rotating, heated disc

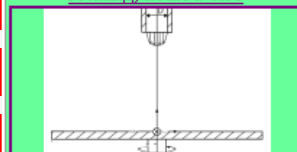

**13.2**

Flow in a 3-D diffuser

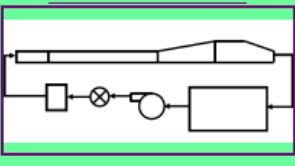

# 解析例

## CASE 8.2: FLOW THROUGH AN ASYMMETRIC PLANE DIFFUSER

### Diffuser geometry:

The  $x$ - and  $y$ -axes are taken in the streamwise and straight-wall normal directions, respectively. The origin of the  $x$ -axis is located at the intersection axis originates from the bottom wall of the downstream channel. Figure 1 illustrates the configuration.

$U_{in}=20 \text{ m/s}$   
 $H=0.015 \text{ m}$   
 $Re=20000$

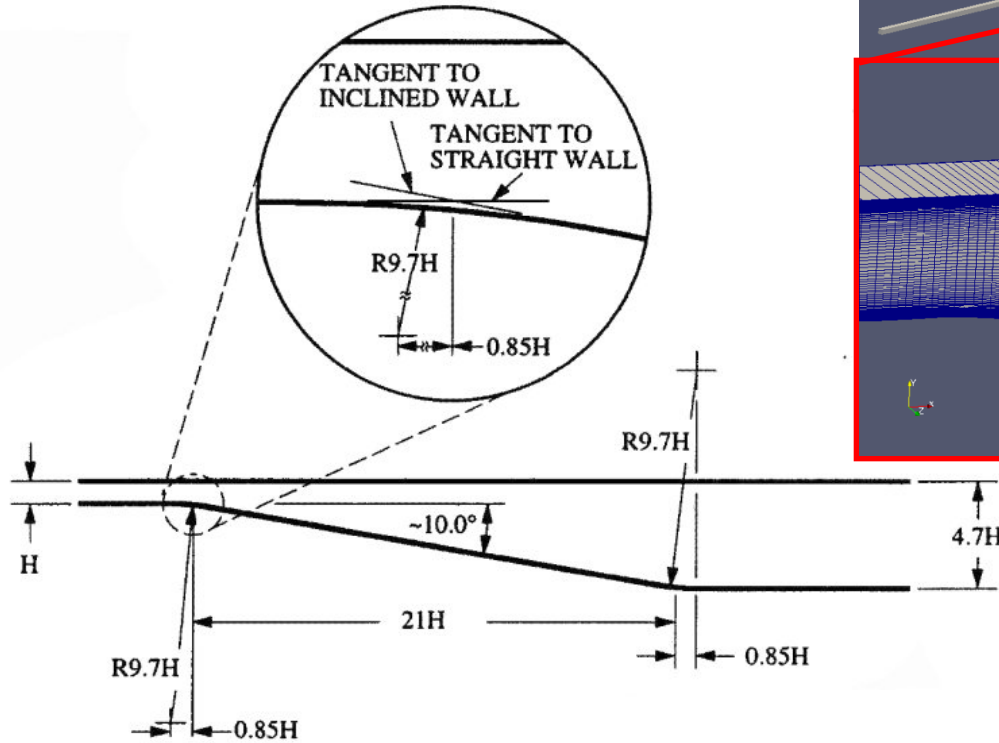
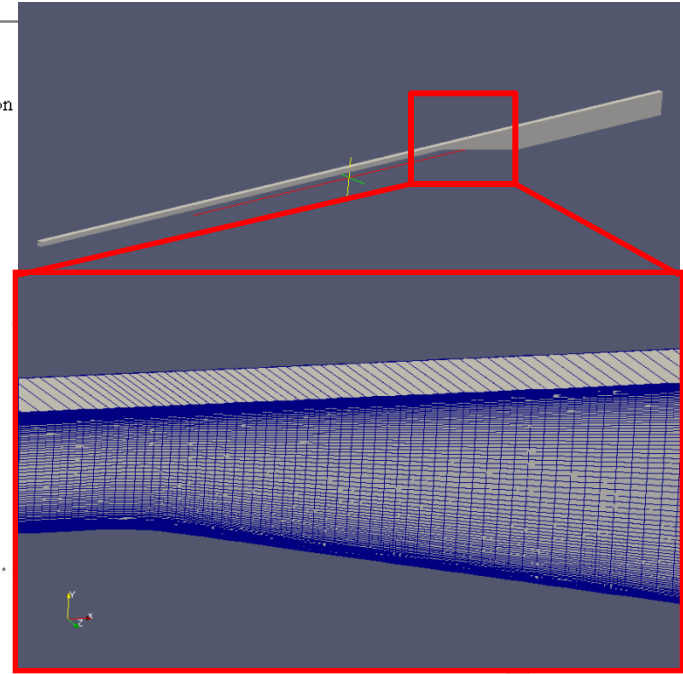

Fig. 1. The geometrical description of the diffuser, from Buice and Eaton.



$y^+ \doteq 1$

### Instructions for Computers

※メッシュは以下のページにあるものから拝借しています  
<http://cfm.mace.manchester.ac.uk/Saturne/WebHome>

流速分布: 斜面上は**SST**、**SA**が良好 → 逆に後流では標準、**RNG**が良好(偶然?)  
 未収束(標準、**RNG**、**Shih**)、収束(**SST**、**SA**)した結果を比較するのに難がある...

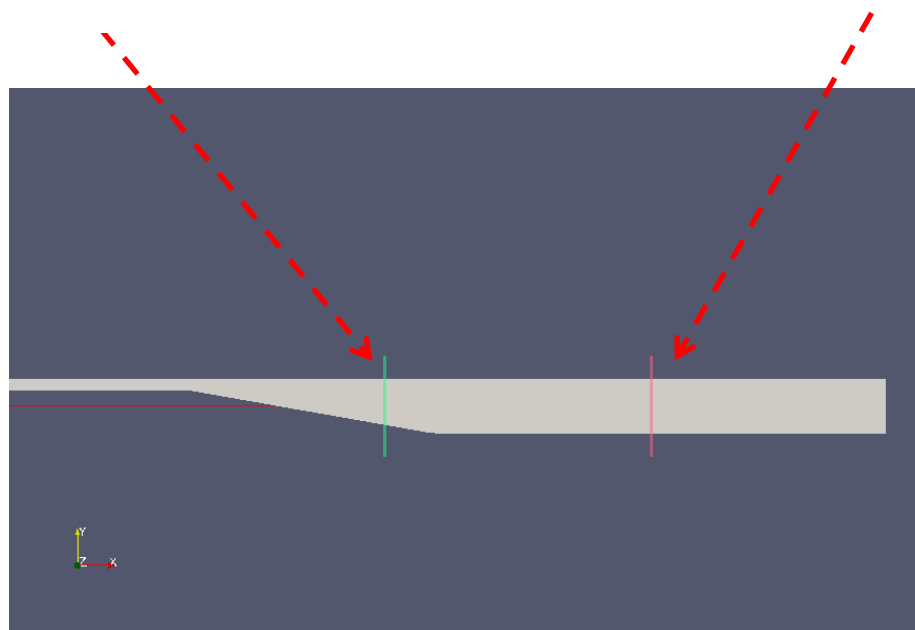
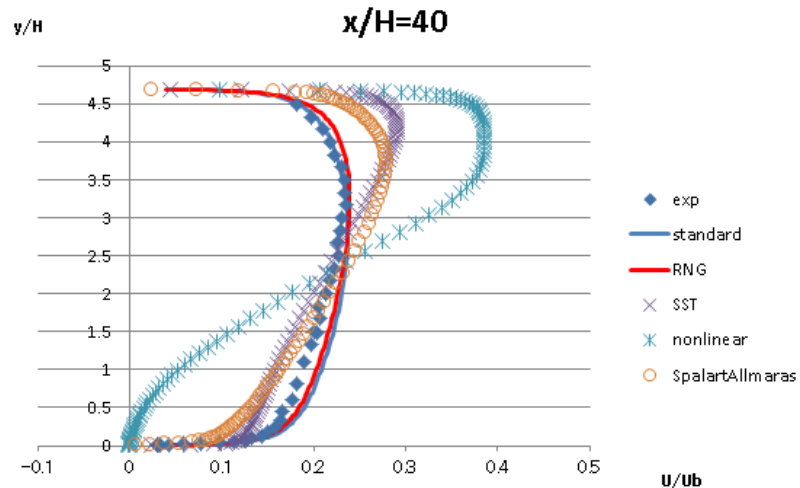
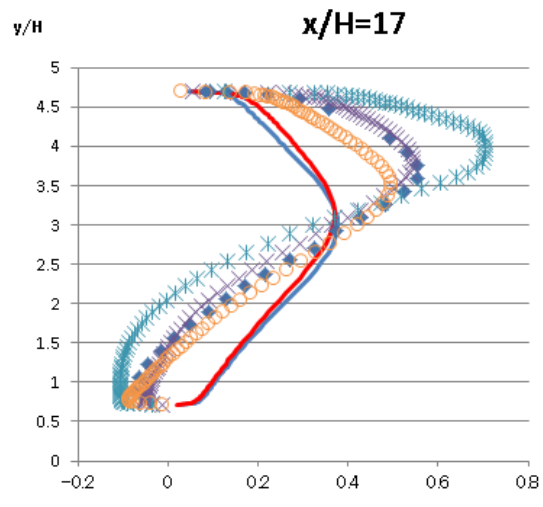

**Re**応力分布:いずれも定量的には合わず、特徴的な**SA**の結果はモデルの特性?  
 後流での流路中心位置のピークは**Shih**のみ近い値に → 非等方モデル故?

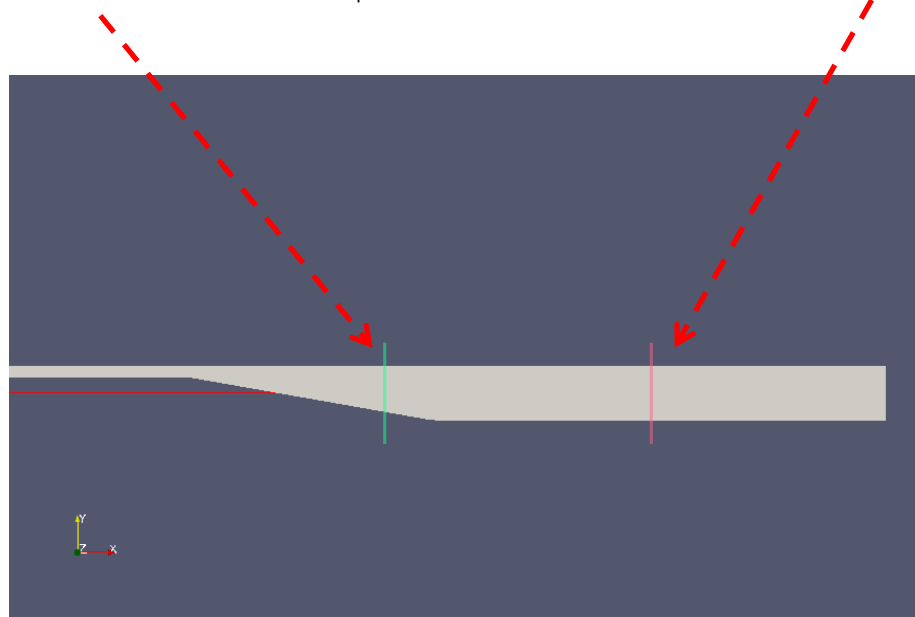
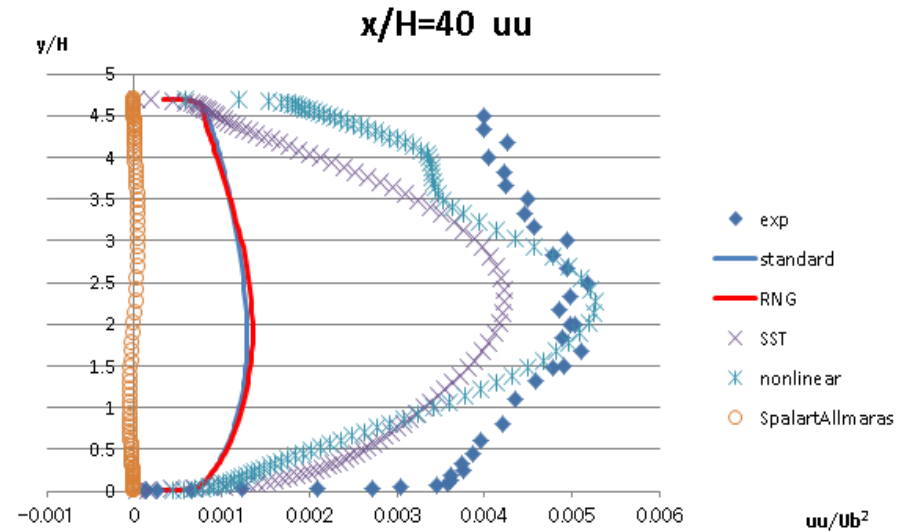
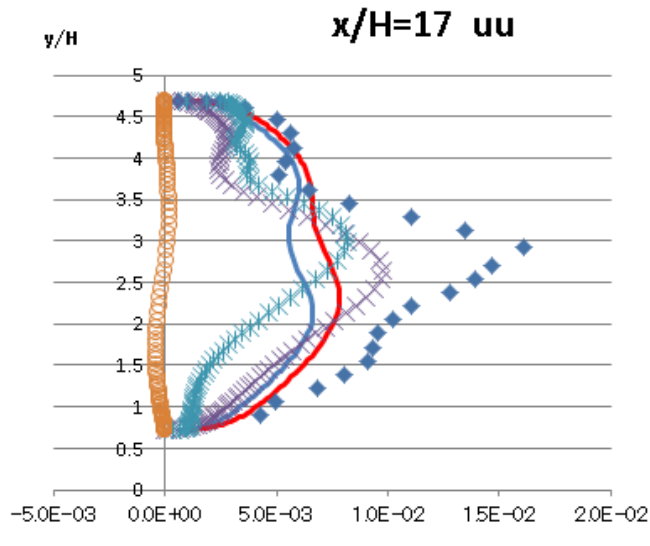

# 今後

## 1. Test caseを一通り揃えたい・・・

- ・後半の方は色々制約があって、モデリングにも難あり。3Dだと解析時間もかかる
- ・容量の制約がなければ、勉強会のwikiページに順次upしていきます
- ・「これ、私やりましょうか」というような参加してくれる方、募集中

## 2. 乱流モデル追加・改良

- ・コード改良という意味で最も手をつけやすい部分(だと個人的に思う)
- ・CFD-onlineにも幾つか置いてある(V2F,  $\gamma$ -Re- $\theta$ など、1.6-extで動作確認)
- ・日本語の文献が豊富(論文だけでなく、参考書レベルでも詳細に書いてある)

→手始めに低Re数モデルを作ってみた(Abe-Nagano-Kondohモデル)

ただし、 $\varepsilon$ の壁面境界の厳密な与え方  $\varepsilon_{wall} = 2\nu(\partial\sqrt{k}/\partial y)^2$  が不明(groovyBC?)

## 3. 連成解析IFツールのインストールと、OFでの動作テスト

- ・国プロで流体-構造のカップリングツールを開発・提供
- ・開発している知り合い(というか、会社の同僚)によれば、コードがあれば、組込可能
- ・毎度のことながらインストールがうまくいってないので、そこをクリアするのが目標